



## Model UHH - Universal Handheld Test Instrument

### Specifications - Installation and Operating Instructions



Front View



Side View

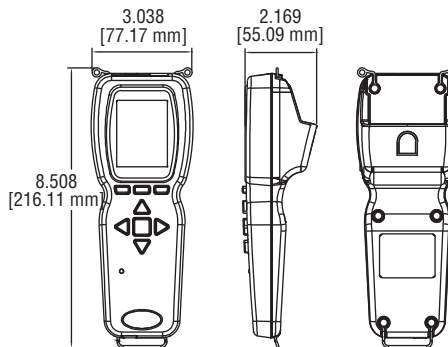

The Model UHH Universal Handheld Test Instrument is a highly versatile instrument that offers the utmost flexibility and ease of user operation by having the capacity to work with a variety of Dwyer Instruments, Inc. compatible sensing modules and probes. Additional wired and wireless probes or modules are instantly recognized by the UHH without any user reprogramming or alteration, allowing seamless sensor addition, upgrade or replacement. See the Dwyer Instruments, Inc. catalog or website [www.dwyer-inst.com](http://www.dwyer-inst.com) for available packages and sensors. The Universal Handheld offers a slew of features that enable a technician to quickly set up and intuitively navigate through their daily activities. Data is stored via the internal memory or separate SD card in various auto or manual logging operations. Logged files can be quickly transferred to a device through a USB cable or by a portable SD card. The display can operate in standard numerical meter mode, gauge mode with analog needle and bar graph, gauge mode with additional pass/fail operation zones, and strip chart mode which enables a simplified visual tracking of the process. The four button directional plus enter button combined with the three soft key buttons aligning to corresponding screen functions allow for quick navigation through the four main operation menus. The rugged plastic case with protective thermo-plastic over-mold along with the dust-shielding rubber caps permit the unit to handle abuse and properly withstand dusty environments. The base UHH includes an integral molded compartment, that securely holds wireless modules. The storage compartment offers convenient transportation of a module with the base instrument during testing. A flexible hand strap included with every UHH provides means for the base handheld to be safely connected to a belt, pipe, ladder or similar structure freeing the user's hands to focus on the sampling test. A 6-pin connector enables one wired probe at a time to be plugged in to the base instrument without worry of becoming disconnected during sampling. The rechargeable battery via the included USB cable provides long term operation to last through several days work. At just under 10 oz, the compact UHH base is lightweight. Included in the standard series kits is a soft carrying case which secures the provided accessories and test probe. The Pro-Series provides the addition of a rugged hard case with foam cut-outs that secures existing as well as additional test sensors and accessories.

#### \*Wireless Guidelines in Accordance with FCC:

Changes not expressly approved by Dwyer Instruments Inc. could void the user's authority to operate the equipment.

This product complies with FCC OET Bulletin 65 radiation exposure limits set forth for an uncontrolled environment.

Pursuant to FCC 15.21 of the FCC rules, changes not expressly approved by Dwyer Instruments, Inc. might cause harmful interference and void the FCC authorization to operate this product.

#### Canadian Government Guidelines:

Operation is subject to the following two conditions: (1) This device may not cause harmful interference and (2) this device must accept any interference received, including interference that may cause undesired operation.

#### INFORMATION TO THE USER

**Power Output:** 6 mW  
**Operating Frequency:** 2.4 GHz  
**Operating Channel:** 11  
**Operating Mode:** IEEE 802.15.4, Zigbee, Direct Sequence Spread Spectrum  
**Data Rate:** Up to 250 kbps  
**Intended Use:** Industrial/commercial HVAC  
**Antenna Connection:** Internal only, non-tunable

#### UHH SPECIFICATIONS

**Languages:** German, Spanish, Italian, English, Portuguese.

**Display:** OLED, color 240 x 320.

**Temperature Limits:** 5 to 125°F (-15 to 51°C).

**Note:** When using wireless

function: 20 to 125°F (-6 to 51°C).

**Battery Charging Limits:** 32 to 113°F (0 to 45°C).

**Resolution:** 1 FPM, 0.1 MPS, 0.1 CFM & M<sup>3</sup>/HR; 0.1°F & °C; RH 0.1%.

**Units Air Velocity:** FPM, MPH, KN, M/H, M/S K/H, FPS.

**Units Flow:** CFM, M<sup>3</sup>/HR, M<sup>3</sup>/S, GPM, GPH, GPD, LPS, LPM, LPH.

**Units Temperature:** °F, °C.

**Handle Enclosure:** Thermoplastic elastomer over polycarbonate.

**Maximum Wireless Distance:** 50' (15 m) typical.

**Power Requirements:** Rechargeable lithium ion polymer via USB.

**Weight:** 10 oz (283 g).

**Supplied With:**

AQTI: Soft case; USB cable/charger; Hand strap;

AQTIP: Soft case; USB cable/charger; Hand strap, 2GB SD card.

**Agency Approval:** IEC 61000-4-2, IEC 61000-4-3, EN 55022, IEC 60601-1-2, EN 300 328, CE with approved charger, RoHS; Note: Intended to be operated with power cables less than 3 m in length, \*FCC Compliance.

#### THERMO ANEMOMETER PROBE SPECIFICATIONS

**Service:** Air velocity and temperature of clean, dry air.

**Temperature Limits:**

Process Air Velocity: -20 to 212°F (-29 to 100°C);

Process Temperature: -40 to 212°F (-40 to 100°C).

Ambient: 5 to 125°F (-15 to 51°C).

Wireless Probe Battery Charging Limits: 32 to 113°F (0 to 45°C).

**Range Air Velocity:** 0 to 6000 FPM (0 to 30 m/s).

**Accuracy Air Velocity:** ±3% FS within temperature range of 40 to 90°F (4 to 32°C).

**Range Volumetric Air Flow:** 999,999 in selected flow units.

**Range Temperature:** -40 to 212°F (-40 to 100°C).

**Accuracy Temperature:** ±0.5°F (±0.28°C) from 32 to 122°F (0 to 50°C); ±1.5°F (±0.83°C) from -40 to 32°F (-40 to 0°C) and 122 to 212°F (50 to 100°C).

**Handle Enclosure:** Thermoplastic elastomer over polycarbonate.

**Probe Length:** 8" (203 mm) insertion.

**Cable Length:** 28" (71 cm) retracted, 6 ft (183 cm) extended.

**Supplied With:** Wrist strap.

**Agency Approval:** EN 55011, EN 61326-1, IEC 61000-4-2, IEC 61000-4-3, EN 55022, RoHS, \*FCC Compliance.

#### HUMIDITY/TEMPERATURE PROBE SPECIFICATIONS

**Service:** Humidity and temperature detection in clean air.

**Temperature Limits:**

Process: -22 to 176°F

(-30 to 80°C);

Ambient: 5 to 125°F (-15 to 51°C).

Wireless Probe Battery Charging Limits: 32 to 113°F (0 to 45°C).

**Range Relative Humidity:** 0 to 100% (non-condensing).

**Accuracy Relative Humidity:** ±2% FS over 10 to 90% @ 77°F (25°C).

**Range Temperature:** -22 to 140°F (-30 to 60°C).

**Accuracy Temperature:** ±0.9°F @ 72°F (±0.3°C @ 25°C).

**Handle Enclosure:** Thermoplastic elastomer over polycarbonate.

**Probe Length:** 8" (203 mm) insertion.

**Cable Length:** 28" (71 cm) retracted, 6 ft (183 cm) extended.

**Supplied With:** Wrist strap.

**Agency Approval:** EN 61000-6-2, EN 61000-6-4, IEC 61000-4-2, IEC 61000-4-3, EN 55011, EN 61326-1, RoHS, \*FCC Compliance.

## UHH FEATURE OUTLINE



### SIDE VIEW

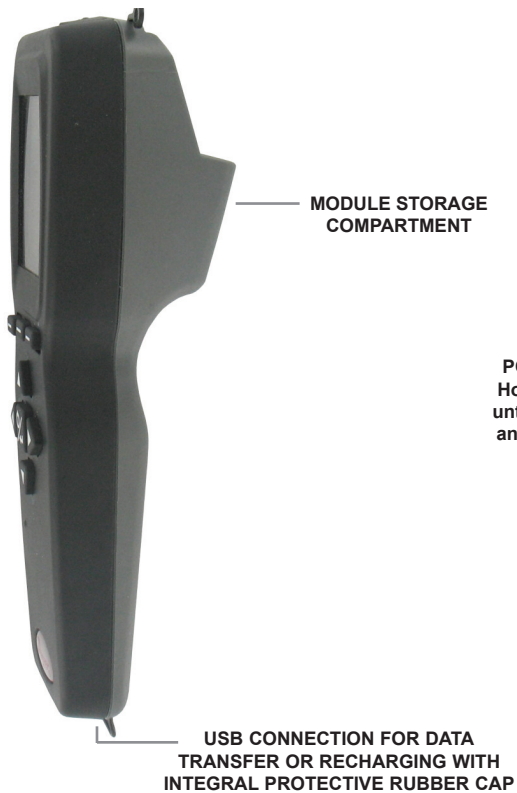

### WIRELESS PROBE



## MENU SETUP

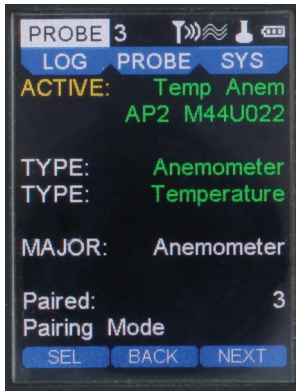

Probe Main Menu

### Probe Menu

- Press the **◀▶** to scroll through the top main menus.
- When **PROBE** is highlighted, hit the enter key.
- The currently active probe connected will appear as well as the parameter types being provided to the UHH. **ACTIVE** will detail the active probe's description, model code and corresponding serial number.
- Select the primary measurement of the home screen under the **MAJOR** setting.
- To alter the potential modes of the measurements, scroll down to any of the **TYPE** sub-menus to select and adjust.



TYPE Sub-Menu Anemometer (Velocity Selected)

- In this example, the **Anemometer** can be changed from either **Velocity** mode or **Vol. Flow** mode.
  - Change the engineering units to be displayed under the **UNITS** section.
- Note:** Some probes or modules may provide a selectable range which can be adjusted here.



TYPE Anemometer Sub-Menu (Vol. Flow Selected)

- Similarly to when **Velocity** is selected, applicable engineering units can be chosen in the **UNITS** category for **Vol. Flow**.
- Note an area must be entered.

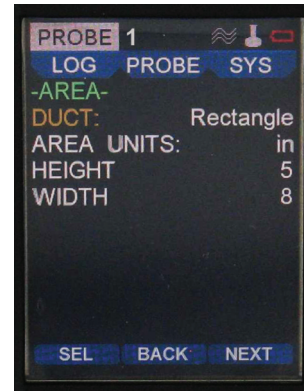

Area Sub Menu (Vol. Flow Selected)

- If **Vol. Flow** is chosen, select the **AREA** category to adjust the **DUCT** style, the **AREA UNITS**, **HEIGHT** and **WIDTH** dimensions.



TYPE Sub-Menu Temperature

- In this example, the **Temperature** range is set and cannot be changed as it is green and unselectable, however the units may be adjusted.

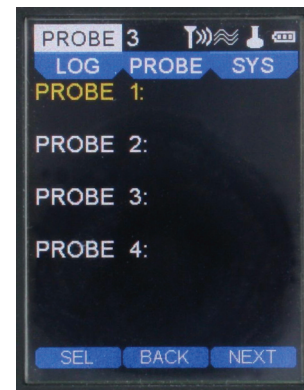

Pairing Mode Sub-Menu

- After placing the UHH into **Pairing Mode**, turn on one wireless probe. After a period of up to 15 to 20 seconds, the UHH screen will update with the information about the wireless probe just turned on.
- Note:** If probe does not appear, power probe down, then power back on.



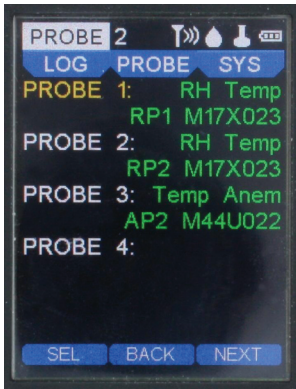

**Pairing Mode Sub-Menu (cont'd)**

- To confirm a proper pairing, select that probe on the list. That probe's details will disappear, meaning that probe has been paired. The details of paired probes will now be visible in the **Paired** sub-menu. Once paired, no other UHH can pair with that probe as long as your UHH is communicating with that probe.
- In **Paired** sub-menu you can see probes that are paired with the UHH. You may delete probes from being paired by selecting. Once deleted, any UHH can pair with that probe.

**SYS Menu**



**SYS Main Menu**

- Press the **◀▶** to scroll through the top main menus.
- When **SYS** is highlighted, push the enter key.
- The **STATUS** will show how many probes are currently paired.
- The **WIRELESS** feature may be turned on or off and the display **CONTRAST** adjusted here as well.
- If desired, a **RESTORE DEFAULT** feature is available from this screen.
- Note: **FILE** displays remaining available memory. If **INT** is selected in the **LOG** main menu the maximum memory is 4 MB. A 2 GB memory card is the maximum memory the UHH can utilize if SD is selected.



**Status Sub Menu**

- If you select the **STATUS** sub menu you can view the firmware edition as well as the UHH device handle.

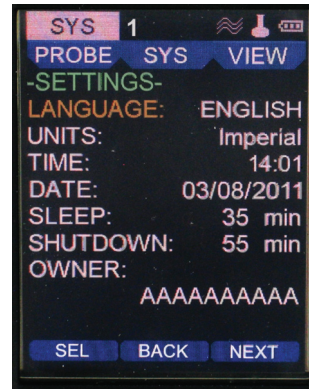

**SETTINGS Sub Menu**

- Click on the **SETTINGS** sub menu for language selection as well as the default engineering units. The **DATE** and **TIME** can be entered, as well as power management inactivity time delays for **SLEEP** and **SHUTDOWN**.
- The user can program in their name, an identification code or their company name into the **SETTINGS** sub menu under **OWNER**.

**VIEW Menu**



**VIEW METER Mode**

- Press the **◀▶** to scroll through the top main menus.
- When **VIEW** is highlighted, select with the enter key.
- Several viewing modes are available on the home screen from the selections in this menu.
- The default is **METER** which displays numerical values.
- The **AVERAGE** setting calculation is programmed in this menu.
- **AVERAGE** values may be altered from 1 to 60 seconds.



## Home Displays Under Standard METER Mode



**CURR View in the Home Screen**

- On the home display, multiple values may be viewed at the same time if a sensor offers.
- If two are present the reading at the top, or **MAJOR** reading, may be switched. See the **Probe** main menu for details.
- Press the soft key on the left aligned with the **HOLD** function to freeze the reading at that instant. The **RUN** function will then appear on the left.
- To resume reading the live process press the left soft key aligned with the **RUN** function.



**AVG Home Screen**

- To see the average reading instead of the current process reading press the soft key in the middle aligned with the **CURR** function so that the **AVG** function is on top. Press the soft key on the right aligned with the **CLEAR** function to reset the average readings.
  - See the **VIEW** main menu to adjust the average function time period.
- Note:** The current process reading will remain visible at the top of the display.



**TOTAL Summation Home Screen**

- To view the sum or total value, again press the middle soft key to scroll from **AVG** to **TOTAL**.
- Note:** Only visible on certain probes.
- Hit the **CLEAR** soft key on the right to reset the total value back to zero and restart the summation.
- Note:** The current process reading will remain visible at the top of the display.



**PEAK VALLEY Home Screen**

- To view the peak and valley values, press the middle soft key one more time to scroll from **TOTAL** to **P/V**.
- Hit the **CLEAR** soft key on the right to instantly reset the peak and valley values and recalculate new peak and valley values.

**Note:** The current process reading will remain visible at the top of the display.



**View GAUGE Mode**

- Choose **GAUGE** mode to display a digital analog gauge like one similar to a speedometer. The available range will be adjustable with min and max scale feature.
  - Adjust both the **min** and **max** for the associated values that will correspond to the 0° value for min and the 180° value for the max or full scale reading.
- Note:** Some probes or modules may have selectable ranges that are programmed in the **PROBE** menu under **RANGE**. You cannot go above this chosen full scale **RANGE** in the **GAUGE** setting in the **VIEW** menu.



**Home View GAUGE Mode**

- In this example, the **min** is zero and the **max** is 500. The live process value is shown under the gauge dial.
- The mid point will always show at the 90° point on the gauge dial.



View RANGE Mode

- An extension from the **GAUGE** mode is the **RANGE** mode.
- Select **RANGE** in the **VIEW** category.
- Two sets of **min** and **max** will appear listed as **GAUGE** and **RANGE**.
- The **GAUGE** settings are just as in the previous **GAUGE** view mode and show the zero and full scale points of the dial.
- The **RANGE low** and **high** settings provide a different color green zone to appear on the dial of the digital gauge. This two color band dial provides a quick determination during a test if the reading is in the pass or fail zone.



Home View RANGE Mode

- In this example, the **GAUGE** has a **min** of 0 and a **max** of 500. The **RANGE low** is 100 while the **high** is 400.
- A green zone on the dial corresponding to the **RANGE low/high** settings will appear on the home screen.



View STRIP Mode

- The fourth and final choice in the **VIEW** menu is **STRIP**. This option offers the user a strip chart style graph with Y axis scaled with the selected major sensor setting and an X axis showing the selected time.
- The x axis time may be adjusted from 10 to 3,600 seconds.



Home View STRIP Mode

- Besides the time setting shown on the graph, you can program the graph to show full scale of the range of the sensor, half scale where the top of the Y axis is half of the full scale, or mid-scale where half the full scale value is displayed in the middle of the Y axis.

### LOG Main Menu



LOG Main Menu

- Press the **◀▶** to scroll through the top main menus.
- When **LOG** is highlighted, push the enter key.
- Here you can program the sampling rate of the logging. The sampling **RATE** may be adjusted from 1 to 3600 seconds between recordings.
- The **FILE FORMAT** can be altered from **CSV** to a **TSV** downloadable file type.
- You can program the **TRIGGER** to be a manual trigger, a trigger begun by a programmed event or a single trigger which manually logs a single point by the push of a button.
- Select the **LOG** to **START** and **STOP** the logging function. The LED will flash when the data sample is stored in any logging mode. A log status icon will also appear at the top to acknowledge a logging session is active.
- After the log session has begun, the file name will appear on the **FILE** row.
- You may select under **MEDIA** to either store data logged files to an **SD** card if one is inserted or to **INT** which is the internal memory.
- Select **LOG FILES** to view all saved files. See view of saved files section for more details.





**LOG TRIGGER Menu**

- If the trigger has been selected to be **Manual** from the **LOG** main menu, the screen will show the three following selections.
- You can change the ending of the log to be either a manual end under **STOP**, or you can set the **STOP** to end after a duration.
- If **DURATION** is chosen the programmed duration determines how long the log session will last. It may be set from 1 to 1,440 minutes.



**LOG TRIGGER Event Menu**

- If the **TRIGGER** has been selected to be **Event** from the **LOG** main menu, the screen will appear as shown.
- **LEVELS** provides initiation points where the trigger will begin a log operation.
- The auto trigger **EVENT** settings can begin **INSIDE** or **OUTSIDE** the **LEVELS** trigger band.
- Setting a **PRE-TRIG** setting to anything other than 0 will provide data recorded to the file for that time period prior to the event trigger initiation.
- **POST-TRIG** sets the duration after the auto trigger event of the log session.
- If the **MIN UPDATE** is set to anything other than 0, a data point will be captured at the time of the **MIN UPDATE** even if the **TRIGGER** threshold has not been reached.
- The **PRE-TRIG** and **POST-TRIG** can be adjusted over a time period, dependent on the sample rate, while the **MIN UPDATE** can be set from 0 to 60 minutes.



**Home View If Single Trigger Chosen**

If **Single** is chosen, no other parameters are necessary to be programmed. This mode will allow with the right soft key located under **STORE** a single data point to be entered into a file. Each subsequent data point will continue to be stored in that same file until the **NEW** soft key is pressed. After **NEW** is pressed, the next set of data points will be stored in a new file.

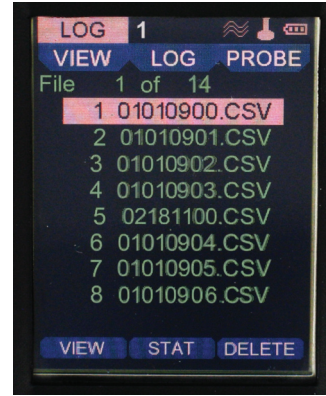

**VIEW of Saved Files**

File names can be scrolled through and their data viewed by selecting **VIEW**. Calculated statistics of the data from a file are viewable such as average or peak and valley by selecting **STAT**. A file may be deleted by hitting **DELETE**. To exit this screen and return to the previous, press the left arrow key.



**VIEW of Saved File**

The following will appear after hitting **VIEW** from the saved files list. Numerical order value in the saved group along with its file name and format, the **DATE**, **TIME** of that data point and the **MAJOR** and **MINOR** data values recorded. To scroll through each data point's information within a file, press the **Δ**/**∇** navigation keys. Any data point may be deleted in their respective file by pressing **DEL**.

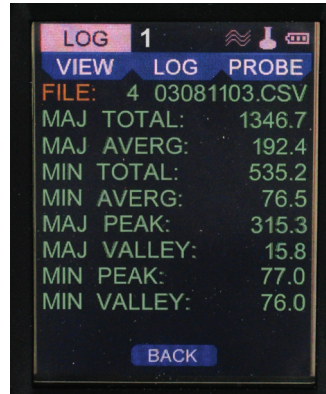

**STAT (Statistics) of a Saved File**

After selecting **STAT** from the saved file list screen you will see statistics for all data within the respective file. Total, Average, Peak and Valley will be visible for both Major and Minor parameters.

**Note:** If there are many stored data points on a file, some time may elapse before the statistics shown above appear.





**Low Battery Warning**

**Low Battery Warning**

The low battery level screen will appear when the UHH detects its charge to be nearing an end. The lithium ion polymer battery is expected to provide approximately 1000 full charge cycles over its lifespan. Once the battery has exceeded its useful lifespan, due to varying regulations regarding shipping lithium batteries, please contact Dwyer Instruments Inc. for details.

**Note:** It is required on the initial usages to fully charge and use until the low battery level screen appears before a second power charge. This will enable the battery icon to properly calculate and display the battery charge level.

**WARNING** Lithium ion polymer batteries are very volatile and can cause a fire if punctured or severely damaged. Only use a Dwyer Instruments, Inc. approved charging device in a well ventilated area away from any flammable materials or gases. Do not incinerate. Only charge between 32 to 113°F (0 to 45°C).

**MAINTENANCE/REPAIR**

Upon final installation of the Series UHH, no routine maintenance is required. The Series UHH is not field serviceable. Contact Dwyer Instruments Inc. for return details (field repair should not be attempted and may void warranty).

**WARRANTY/RETURN**

Refer to "Terms and Conditions of Sales" in our catalog and on our website. Contact customer service to receive a Return Goods Authorization number before shipping the product back for repair. Be sure to include a brief description of the problem plus any additional application notes.

**ACCESSORIES**

Model	Description
AP1	Thermo anemometer air velocity & temperature probe with coiled cable
RP1	Thermo hygrometer & temperature probe with coiled cable
AP2	Wireless thermo anemometer air velocity & temperature probe
RP2	Wireless thermo hygrometer humidity & temperature probe
UHH-STRAP	UHH hand strap
UHH-ICHRG	UHH charger with international adapters
UHH-CBL	USB cable
UHH-SD	2GB SD card
UHH-C1	Soft carrying case
UHH-C2	Heavy duty hard case with pre-cut foam inserts for additional sensor storage.

